

The radio receiver operates in a non-benign environment. It needs to pick out a very weak wanted signal from a background of noise at the same time as it rejects a large number of much stronger unwanted signals. These may be present either fortuitously as in the case of the overcrowded radio spectrum, or because of deliberate action, as in the case of Electronic Warfare. In either case, the use of suitable devices may considerably influence the job of the equipment designer.

Dynamic range is a 'catch all' term, applied to limitations of intermodulation or phase noise: it has many definitions depending upon the application. Firstly, however, it is advisable to define those terms which limit the dynamic range of a receiver.

INTERMODULATION

This is described as the 'result of a non linear transfer characteristic'. The mathematics have been exhaustively treated and Ref.1 is recommended to those interested.

The effects of intermodulation are similar to those produced by mixing and harmonic production, in so far as the application of two signals of frequencies f_1 and f_2 produce outputs of $2f_1 - f_2$, $2f_1$, $2f_2$ etc. The levels of these signals are dependent

upon the actual transfer function of the device and thus vary with device type. For example a truly square law device such as a perfect FET, produces no third order products ($2f_2 - f_1$, $2f_1 - f_2$). Intermodulation products are additional to the harmonics $2f_1$, $2f_2$, $3f_1$, $3f_2$ etc. Fig.1 shows intermodulation products diagrammatically.

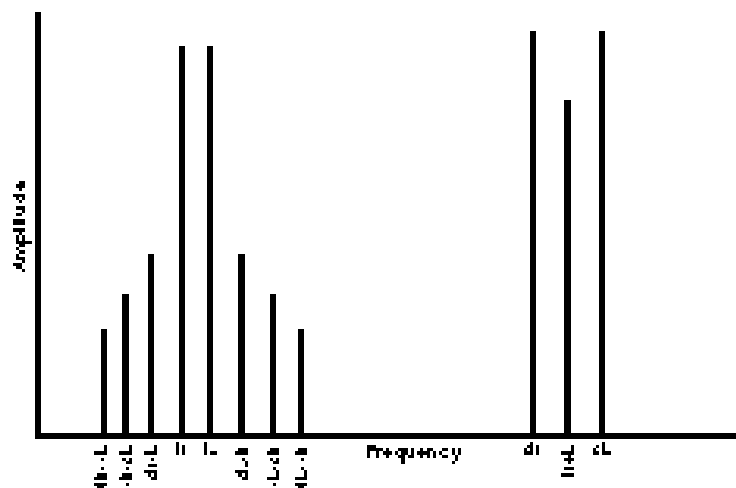

Fig. 1 Intermodulation Products

The effects of intermodulation are to produce unwanted signals and these degrade the effective signal to noise ratio of the wanted signal. Consider firstly the discrete case of a weak wanted signal on 7.010MHz and two large unwanted signals on 7.020 and 7.030MHz. A third order product ($2 \times 7.02 - 7.03$) falls on the wanted signal, and may completely drown it out. Fig.2 shows the total HF spectrum from 1.5 to 41.5MHz and Fig.3 shows the integrated power at the front end of a receiver tuned to 7MHz. It may be seen that just as white light is made

up from all the colours of the spectrum, so the total power produced by so many signals approximates to a large wide band noise signal. Now, it has already been shown that two signals, f_1 and f_2 , produce third order intermodulation products of $2f_1 - f_2$ and $2f_2 - f_1$. The signals will produce third order products somewhat greater in number, viz: $2f_1 - f_2$, $2f_1 - f_3$, $2f_2 - f_1$, $2f_2 - f_3$, $2f_3 - f_1$, and $2f_3 - f_2$. An increase in the number of input signals will multiply greatly the effects of intermodulation, and will manifest as a rise in the noise floor of the receiver.

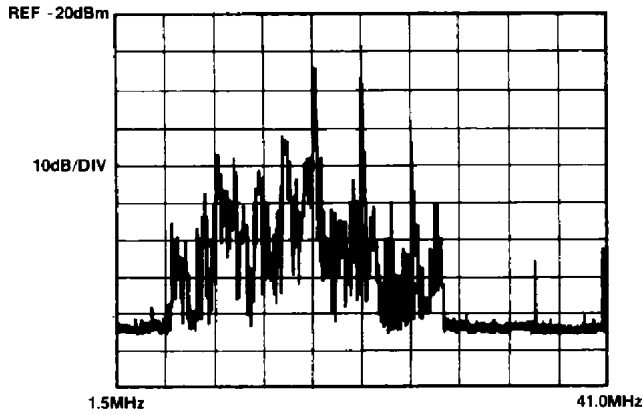

Fig. 2

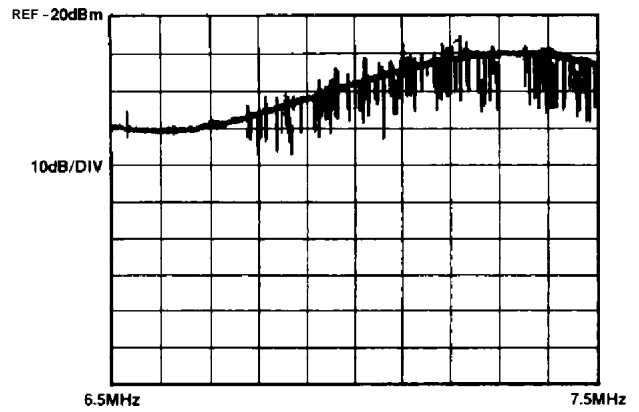

Fig. 3

The amplitude relationships of the third order intermodulation products and the fundamental tones may be derived from Ref.1, where it is shown that the intermodulation product amplitude is proportional to the cube of the input signal level. Thus an increase of 3dB in input level will produce an increase

of 9dB in the levels of the intermodulation products. Fig.4 shows this in graphic form, and the point where the graphs of fundamental power and intermodulation power cross is the *Third Order Intercept Point*.

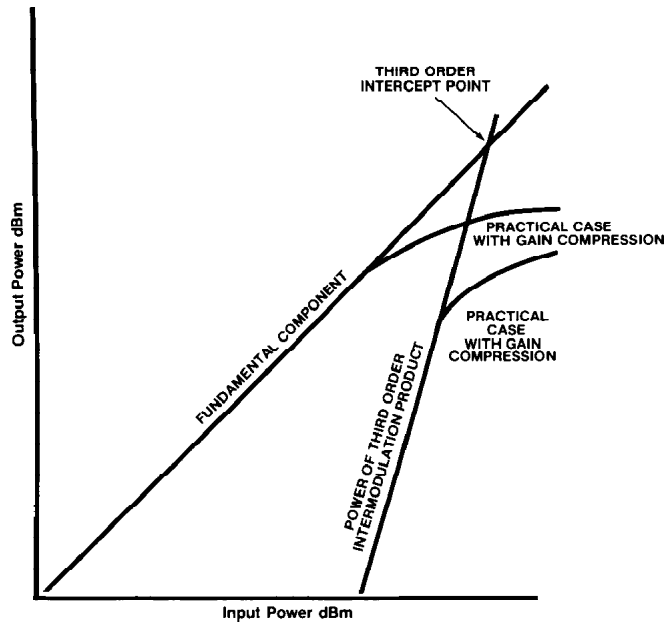

Fig. 4 3rd order intercept

The third order intercept point is, however, a purely theoretical concept. This is because the worst possible intermodulation ratio is 13dB (Ref.2), so that in fact the two graphs never cross. In addition, the finite output power capability of the device leads to *Gain Compression*.

Thus, it is apparent that the intermodulation produced noise floor in a receiver is related to the intercept point. Figs.5, 6 and 7 show the noise floor produced by various intercept points, in a receiver fed from an antenna - a realistic test! Fig.5 shows that a large number of signals are below the noise floor and are thus lost; this represents a 0dBm intercept point. Fig.7 shows a +20dBm intercept noise floor, and it is obvious that many more signals may be received.

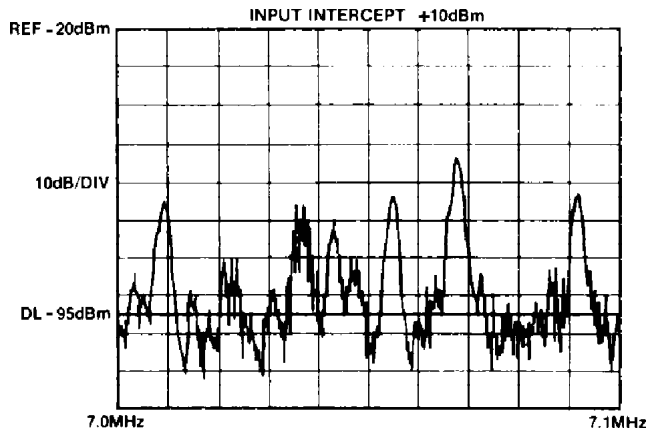

Fig. 6

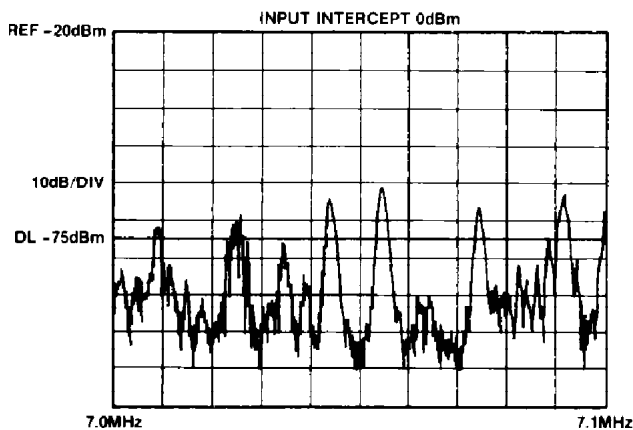

Fig. 5

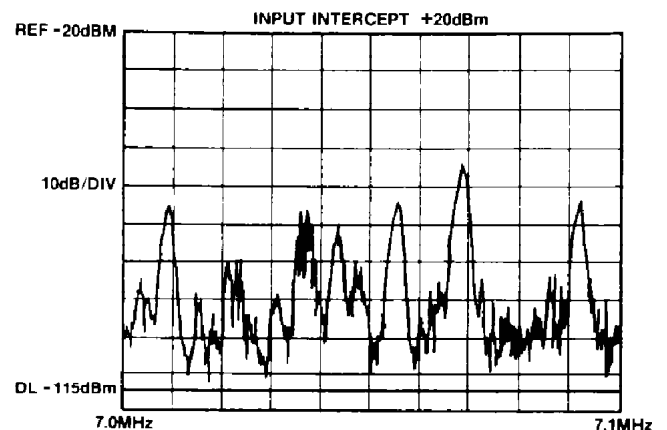

Fig. 7

Because of the rate at which intermodulation products increase with input level (3dB on the intermodulation products for 1dB on the fundamental), the addition of an attenuator at the front end can improve the signal to noise ratio, as an increase in attenuation of 3dB will reduce the wanted signal by 3dB, but the intermodulation will decrease by 9dB. However, it is a fair comment that aerial attenuators are an admission of defeat, as suitable design does not require them!

The concept of dynamic range is often used when discussing intermodulation. Fig.8 shows total receiver dynamic range, which is defined as the spurious Free Dynamic Range. Obviously an intermodulation product lying below the receiver noise floor may be ignored. Thus the usable dynamic range is that input range between the noise floor and the input level at which the intermodulation product reaches the noise floor. In fact

$$DR = \frac{2}{3} (I_3 - NF) \quad \dots (1)$$

Where DR is the dynamic range in dB
 I_3 is the intermodulation input intercept point in dBm
 NF is the noise floor in dBm.

Note that in any particular receiver, the noise floor is related to the bandwidth; dynamic range is similarly so related.

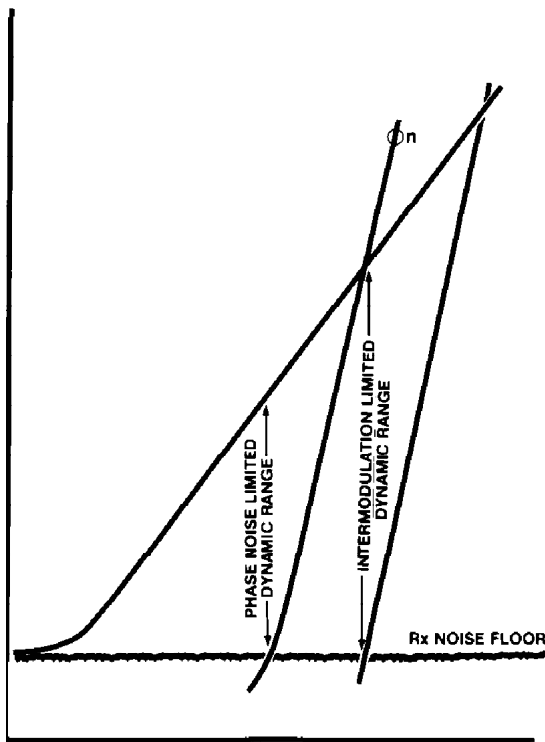

Fig. 8

HF receivers will often require input intercept points of +20dBm or more. The usable noise factor of HF receivers is normally 10-12dB: exceptionally 7 or 8dB may be required when small whip antennas are used. An SSB bandwidth would have a dynamic range from (1) of 105.3dB. The same receiver with a 100Hz CW bandwidth would have a dynamic range of 114.6dB and thus dynamic range is quite often a confusing and imprecise term.

Appendix A defines a quantitative method of Intermodulation Noise Floor assessment, developed later than the data in Figs.5 to 7.

VHF receivers require noise figures of 1 or 2dB for most critical applications, and where co-sited transmitters are concerned, signals at 0dBm or more are not uncommon. However, such signals are usually separated by at least 5% in frequency and filters can be provided. Close-in signals at levels of -20dBm are not uncommon, and dynamic ranges in SSB bandwidths of about 98dB are required.

The achievement of high input intercept points and low noise factors is not necessarily easy. The usual superhet architecture follows the mixer with some sort of filter, frequently a crystal filter, and the performance of this filter may well limit the performance. Crystal filters are not the linear reciprocal two-port networks that theory suggests, being neither linear nor reciprocal. It has been suggested that the IMD is produced by ferrite cored transformers, but experiments have shown that ladder filters with no transformers suffer similarly. Thus, although ferrite cored transformers can contribute, other mechanisms dominate in these components. The most probable is the failure of the piezo-electric material to follow Hooke's Law at high input levels, and possibly the use of crystal cuts other than AT could help insofar as the relative mechanical crystal distortion is reduced. The use of SAW filters is attractive, since they are not bulk wave devices and do not suffer to such an extent from IMD; however, it is necessary to use a resonant SAW filter to achieve the necessary bandwidths and low insertion losses.

The design of active components such as amplifiers is relatively straightforward. Amplifiers of low noise and high dynamic range are fairly easy to produce, especially with transformer feedback, although where high reverse isolation is required, care must be taken. Mixers are, however, another matter.

Probably the most popular mixer is the diode ring (Fig.9). Although popular, this mixer does have some drawbacks, which have been well documented. These are:

- Insertion loss (normally about 7dB)
- High LO drive power (up to +27dBm)
- Termination sensitive (needs a wideband 50)
- Poor interport isolation (40dB)

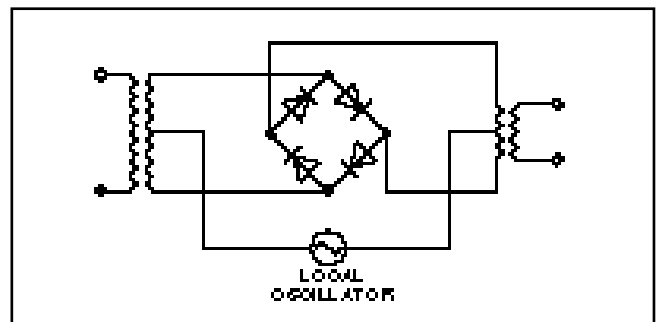

Fig. 9 Diode ring

The insertion loss is a parameter which may be classed merely as annoying, although it does limit the overall noise figure of the receiving system. The high LO drive power means a large amount of DC is required, affecting power budgets in a disastrous way, while termination sensitivity may mean the full potential of the mixer cannot be realised.

For the diode ring to perform adequately, a good termination 'from DC to daylight' is required - definitely at the image frequency ($LO \pm sig. freq.$) - and preferably at the harmonics as well. Finally, interport isolation of 40dB with a +27dBm LO still leaves -13dBm of LO radiation to be filtered or otherwise suppressed before reaching the antenna.

A further problem with the simple diode ring of this form is that the 'OFF' diodes are only Ω by the forward voltage drop of the ON diodes. Thus the application of an input which exceeds this OFF voltage leads to the diodes trying to turn ON, giving gain compression and reduced IMD performance.

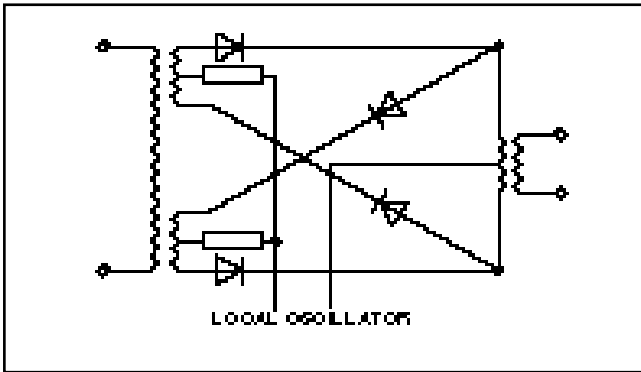

Fig. 10 Resistive loaded high intercept point mixer

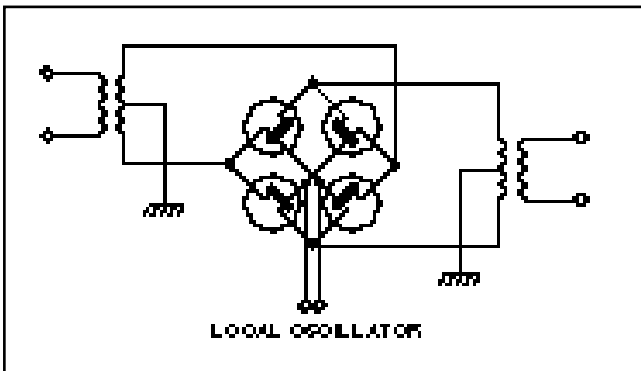

Fig. 11 Quad MOSFET commutative mixer

Fig.10 shows a variation of this in which series resistors are added. The current flow through these resistors increases the reverse bias on the OFF diodes which gives a higher gain compression point: such a mixer can give +36dBm intercept points with a +30dBm of LO drive. Nevertheless, as is common to all commutative mixers, the intermodulation performance is related to the termination, and the LO radiation from the input port is relatively high.

Variations of this form of mixer include the Rafuse Quad MOSFET mixer of Fig.11, which suffers with many of the same problems. Fig.12 shows a dual VMOS mixer capable of good performance, but requiring a large amount of DC power and with limited isolation of the LO injection.

Many advantages accrue to the choice of the transistor tree type of approach (Fig.13). Here the input signal produces a current in the collectors of the lower transistors and this current is commutated by the upper set of switching transistors. Because the current is to a first order approximation independent of collector voltage, the transistor tree does not exhibit the sensitivity to load impedance that the diode ring does, and indeed, by the use of suitable load impedances, gain may be achieved. The non-linearity of the voltage to current conversion in the base emitter junctions of the bottom transistors is the major cause

of intermodulation, but by using suitably large transistors and emitter degeneration, very high performances (+32dBm input intercept) can be achieved.

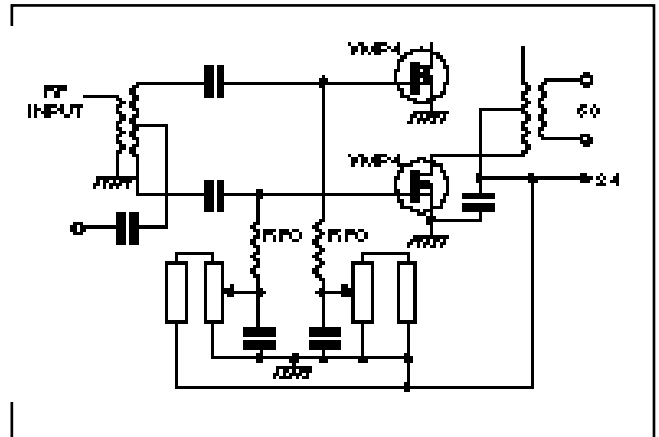

Fig. 12 VMOS mixer

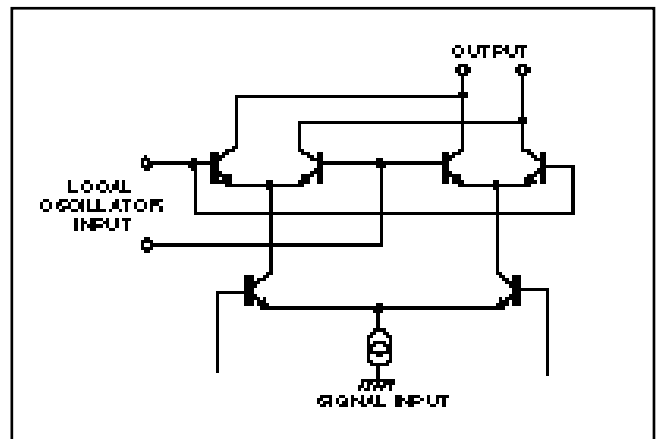

Fig. 13 The transistor tree

PHASE NOISE

The mixing process for the superhet receiver is shown in Fig.14, where an incoming signal mixes with the local oscillator to produce the intermediate frequency. Fig.15 shows the effect of noise modulation on the LO, where the noise sidebands of the LO mix with a strong, off channel signal to produce the IF. This means that the phase noise performance of the LO affects the capability of the receiver to reject off channel signals, and thus the receiver selectivity is not necessarily defined by the signal path filters. This phenomena is referred to as *Reciprocal Mixing*, and has tended to become more prominent with the increased use of frequency synthesisers in equipments.

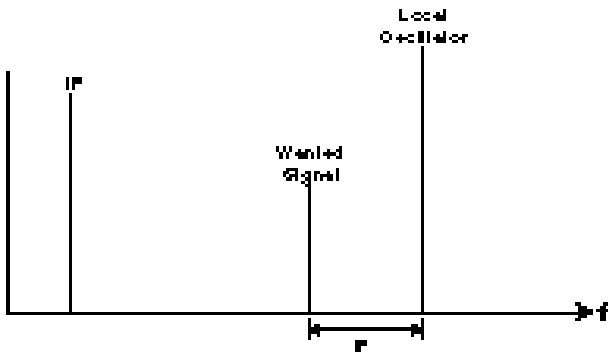

Fig. 14 Superhether mixing

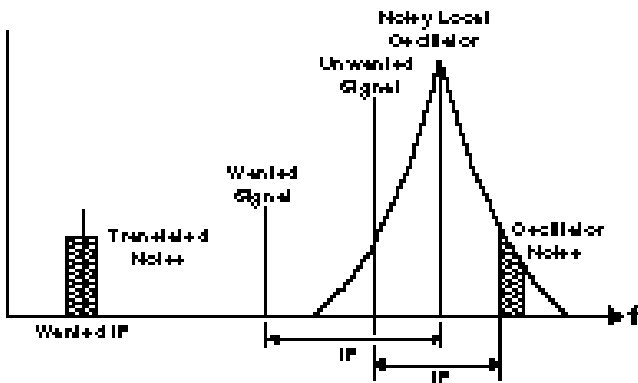

Fig. 15 Reciprocal mixing

The performance level requirements of receivers is dependent upon the application. Some European mobile radio specifications call for 70dB of adjacent channel rejection, equating to some -122dBc/Hz, while an HF receiver requiring 60dB rejection in the adjacent sideband needs -94dBc/Hz at a 500Hz offset. The use of extremely high performance filters in the receiver can be completely negated if the phase noise is poor. For example, a receiver using a KVG XF9B filter with a rejection in the unwanted sideband of 80dB at 1.2kHz, would require a local oscillator with -114dBc/Hz phase noise at 1.2kHz if the filter performance was not to be degraded.

To put these levels in perspective, relatively few signals generators are adequate to the task of being the LO in such a system. For example, 'Industry Standards' like the HP8640B are not specified to be good enough: neither are the HP8642, Marconi 2017/2018, or Racal 9082, all of which are modern, high performance signal generators.

All this suggests that it is very easy to over-specify a receiver in terms of selectivity, and simple synthesisers are not necessarily ideal in all situations.

The ability of the receiver to receive weak wanted signals in the presence of strong unwanted signals is therefore determined not only by the intermodulation capabilities of the receiver, but by phase noise and filter selectivity.

The usual approach to high performance synthesis has used multiple loops for good close-in performance. Notable exceptions are those equipments using fractional N techniques with a single loop. Nevertheless, such equipments not generally specified as highly as multi-loop synthesisers. A vital part of the synthesiser is still the low noise VCO, for which many approaches are possible. This VCO performance should not be degraded by the addition of the synthesiser: careful choice of technologies is therefore essential. For example, Gallium Arsenide dividers are much worse in phase noise production than silicon, and amongst the silicon technologies, TTL is better than ECL.

From equation (1)

$$DR = \frac{2}{3} (I_{p3} - NF) \text{ dB}$$

where I_{p3} = input intercept point dBm
 NF = noise floor dBm

The phase noise governed dynamic range is given by

$$DR = P_n + 10 \log_{10} B \text{ Db} \quad (2)$$

Where P_n is the phase noise spectral density in dBc/Hz at any offset and B is the IF bandwidth in Hz.

(N.B. This is not quite correct if B is large enough such that noise floor is not effectively flat inside the IF bandwidth).

Ideally the ratio.

$$\frac{DR_{IM}}{DR}$$

should be 1 in a well designed receiver - i.e. the dynamic range limited by phase noise is equal to the dynamic range limited by intermodulation.

Certain aspects of low noise synthesiser design have been touched upon and Ref.6 provides further information.

The performance of a receiver in terms of its capabilities to handle input signals widely ranging in input level is dependent upon the receiver capability in terms of intermodulation and phase noise. Neglect of either of these parameters leads to performance degradation, and it has been shown that specifications are not only often difficult to meet, but sometimes contradictory in their requirements.

REFERENCES

1. Broadband Amplifiers Application Notes, Appendix 3, GEC Plessey Semiconductors, Cheney Manor, Swindon, England.
2. Ideal Limiting Part 1, George S.F and Wood, 3W, Washington D.C.: U.S. Naval Research Laboratory AD266069, 2nd October, 1961.
3. The SL6440 High Performance Mixer, P E Chadwick, Wescon Proceedings Session 24, Mixers for High Performance Radio Published by Electronic Conventions Inc., 999 North Sepulveda Blvd. El Segundo, CA., 90245.
4. High Performance Integrated Circuit Mixers, P.E. Chadwick. Clark Maxwell Commemorative Conference on Radio Receivers and Associated Systems, Leeds 1981. Published by I.E.R.E., Savoy Hill House, Savoy Hill, London. Conf. Pub.49.
5. The SL6440 High Performance Mixer, P.E. Chadwick. R.F. Design, June 1980.
6. Frequency Synthesisers. Vadim Manassewitsch, Wiley & Sons, 1980 ISBN 0-471-07917 0.

APPENDIX A

Intermodulation is caused by odd order curvature in the transfer characteristic of a device. If two signals f_1 and f_2 are applied to a device with third order term in its transfer characteristic, the products are given by:

$$(\text{Cos}f_1 + \text{Cos}f_2)^3 = \text{Cos}^3f_1 + 3\text{Cos}^2f_1 \text{Cos}f_2 + 3\text{Cos}f_1\text{Cos}^2f_2 + \text{Cos}^3f_2$$

from the trig identities Cos^3A , Cos^2A and $\text{Cos}A\text{Cos}B$, this is

$$\frac{1}{4}\text{Cos}^3f_1 + \frac{3}{4}\text{Cos}f_1 + \frac{3}{2}\text{Cos}^2f_1\text{Cos}f_2 + \frac{3}{2}\text{Cos}f_1\text{Cos}^2f_2 + \frac{3}{4}\text{Cos}f_2 + \frac{1}{4}\text{Cos}^3f_2 + \frac{3}{4}\text{Cos}f_2$$

(where $f_1 = A$ and $f_2 = B$). Neglecting coefficients, the terms $\text{Cos}^2f_1 \text{Cos}f_2$ and $\text{Cos}f_1 \text{Cos}^2f_2$ are equal to

$$\text{Cos}(2f_1 + f_2) + \text{Cos}(2f_1 - f_2) \text{ and}$$

$$\text{Cos}(2f_2 + f_1) + \text{Cos}(2f_2 - f_1)$$

By inspection, it may be seen that frequencies off $f_1, f_2, 3f_1, 3f_2, (2f_1 \pm f_2)$ and $(2f_2 \pm f_1)$ are present in the output. Of these, only $2f_2 - f_1$, and $2f_1 - f_2$ are close to wanted frequencies f_1 and f_2 . The application of three signals f_1, f_2 and f_3 , produces a similar answer, in that the resulting products are:

$$3f_1, 3f_2, 3f_3, f_1 + f_2 + f_3, f_1 + f_2 - f_3, f_1 - f_2 + f_3, f_1 - f_2 - f_3, f_2 - f_1 + f_3, f_2 - f_1 - f_3, -f_1 - f_2 - f_3, -f_1 - f_2 + f_3$$

in addition to the products

$$2f_1 \pm f_2, 2f_2 \pm f_1, 2f_2 \pm f_3, 2f_3 \pm f_2, 2f_1 \pm f_3, 2f_3 \pm f_1$$

if a greater number of signals are applied such that the input may be represented by:

$$\text{Cos}f_1 + \text{Cos}f_2 + \text{Cos}f_3 + \text{Cos}f_4 \dots \text{Cos}f_n$$

The result from third order curvature can be calculated from:

$$(\text{Cos}f_1 + \text{Cos}f_2 + \text{Cos}f_3 + \text{Cos}f_4 \dots \text{Cos}f_n)^3$$

This expansion produces terms of

$\text{Cos}(f_1 \pm f_2 \pm f_3), \text{Cos}(f_1 \pm f_2 \pm f_4), \text{Cos}(f_1 \pm f_2 \pm f_n)$, etc from which it can be seen that the total number of products is:

$$\frac{n!}{3!(n-3)!} = 4 \times \frac{1}{6}n(n-1)(n-2)$$

(The factor of 4 appears because each term has four possible sign configurations i.e. $\text{Cos}(f_1 + f_2 + f_3), \text{Cos}(f_1 + f_2 - f_3)$ etc). This agrees with Ref A1.

By a similar reasoning, n signals produce:

$2n(n-1)$ products of the form $(2f_1 \pm f_2) (2f_2 \pm f_1)$ etc and n 3rd harmonics.

Thus the total number of intermodulation products produced by third order distortion is:

$$n + 2n(n-1) + \frac{2}{3}n(n-1)(n-2) \tag{1}$$

Reduction of the input bandwidth of the receiver modifies this. Consider, for example, a receiver with sub-octave filters, rather than the 'wide-open' situation analysed above. In this case, the third harmonics produced by any input signals will not fall within the tune band, as will some of the products such as $f_1 + f_2 + f_3, f_1 - f_2 - f_3$, etc. In this case, the total number of intermodulation products is reduced. There are only three possible sets of products of the form $f_1 \pm f_2 \pm f_3$, i.e. $f_1 + f_2 - f_3, f_1 - f_2 + f_3$ and $f_3 - f_1 - f_2$ which can give products within the band. Note that for products to be considered, they must have an effective input frequency at the receiver mixer equivalent to an on-tune desired signal. In addition, products of the form $2f_1 + f_2, 2f_2 + f_1$ etc are again out of band. Thus half of the $2n(n-1)$ products of this class are not able to cause problems and the total number of products to be considered is now:

$$n(n-1) + \frac{1}{2}n(n-1)(n-2) \tag{2}$$

This result does not agree with Barrs (Ref A2) who uses the results in (1). The results in (2) are an absolute worst case, insofar as a number of the intermodulation products are out of band.

(For the purposes of this analysis, IMD in a mixer is assumed to produce an 'on tune' signal. Thus not all the possible intermodulation frequencies appearing in a half octave bandwidth will be able to interfere).

The same arguments apply to narrower front end bandwidths. However, the narrower the front end bandwidth, the higher is the probability that the distribution of signals will produce IMD products outside the band. For example, a receiver with $\pm 2.5\%$ front end bandwidth tuned to 10MHz will accept signals in a band from 9.75 to 10.25MHz. Signals capable of producing a product of the form $2f_1 - f_2$ must have one of the signals (f_1 or f_2) in the band 9.875 - 10.25 for a product to appear on tune. Thus the two signal apparent bandwidth is less than would be expected. Similar constraints apply to the $f_1 + f_2 - f_3$ product.

Similar arguments apply to other orders of curvature. Second order curvature, for example, will not produce any products in band for input bandwidths of less than 2:1 in frequency ratio.

The actual levels of intermodulation produced can be predicted from reference A1. In practice, the situation is that the input signals to a receiver are rarely all of equal unvarying amplitude and assumptions are made from the input intercept points and the input signal density.

If a series of amplitude cells are established for given frequency ranges, such as that in Table 1, then a prediction of the number of intermodulation products for any given number of input signals and amplitudes may be obtained, either from equation (1) or (2) (as applicable) or from Ref A1 (for higher orders). Where the input bandwidth of the receiver is deliberately minimised, the maximum cell size in the frequency domain should be equal to the input bandwidth.

The total input power in each cell is

$$nP_{av}$$

where n is the number of signals and P_{av} is the average power of each signal.

A worst case situation is to assume that all signals in the cell are equal to the cell upper power limit boundary, e.g. if the cell amplitude range is from -40 to -30dBm, then an assumption that all signals in this cell are at -30dBm is a worst case.

If, however, it is assumed that signals will have a Gaussian distribution of input levels within a cell, then the total input power becomes:

$$P_t = 0.55nP$$

where P_t is the total power

n is the number of signals

P is the power level at the upper boundary of the cell

Because the total IMD power is the sum of all the IMD powers, the average input power is

$$P_{av} = \frac{0.565nP}{n}$$

The IMD power produced by third order curvature is:

$$10 \log_{10} \left[\frac{1}{3} n(2n^2 + 1) \right] \text{Antilog} \frac{1}{10} [P_{av} - 3(I_3 - P_{av})] \text{dBm}$$

where P_{IM} is the total power of the intermodulation products

I_3 is the third order input intercept point

Because the coefficients of the amplitudes of the intermodulation products are (depending on product)

$$a^3, a^2b, ab^2, abc, b^3$$

where a, b and c are approximately equal, the use of a^3 as the general coefficient is justified.

From equations (1) or (2) and (3), the total IMD power and number of products may be calculated. As 'n' increase in number, the number of products will mean that the resultant IMD tends more to a noise floor increase in the receiver, thus reducing the effective sensitivity.

The amount of this degradation is such that the noise floor is:

$$\frac{2}{3} \frac{(0.55nP)^3}{I_3} \times \frac{I_3}{(f_{max} - f_{min})} \times f$$

where $(f_{max} - f_{min})$ is the bandwidth prior to the first intermodulating stage. f is signal bandwidth in a linear system.

The Gaussian Factor of 0.55 is somewhat arbitrary, since errors in this assumption are cubed.

The intermodulation Limited Dynamic Range is

$$\frac{2}{3} (I_3 + 174 - 10 \log_{10} f - NF)$$

where NF is the Noise Figure in dB.

The effects of Reciprocal Mixing are similar, except that signals may be taken one at a time. The performance is affected by the frequency separation between an 'off-tune' interfering signal and an 'on-tune' wanted signal unless the separation is such that the oscillator noise floor has been reached. Here again, reduction of front end bandwidth reduces the number of signals.

Generally speaking, the effects of reciprocal mixing are limited to close in effects - say within $\pm 50\text{kHz}$, unless very poor synthesisers are used.

The response at some separation f_0 from the tune frequency is: $(L - 10 \log_{10} 10 f)$ dB where L is phase noise spectral density in dBc/Hz and f is the IF bandwidth.

This assumes that the spectral density does not change within the receiver bandwidth: Ref A1 shows this to be generally applicable for narrow bandwidths.

The intermodulation free dynamic range is defined as:

$$\frac{2}{3} [I_3 - \text{noise floor}] = \frac{2}{3} [I_3 + 174 - 10 \log_{10} f - NF] \text{dB}$$

where I_3 is the input 3rd order intercept point in dBm

NF is the noise figure in dB

f is the IF bandwidth in Hz

It has been claimed that there is 6dB rejection of phase noise in diode commutative mixers. Thus the relationship between IMD and phase noise can be expressed as:

$$\text{IMD dynamic range} = \text{phase noise dynamic range} + 6\text{dB} = (L - 10 \log_{10} f) + 6\text{dB}$$

Thus at any offset, it is important to ensure that the two dynamic ranges are approximately equal if performance is not to be compromised.

A receiver for example with an input intercept point of +20dBm and input signals of -30dBm will produce an IMD product at -130dBm which, for an HF receiver with a noise factor of 8dB, will be just above the noise floor, in an SSB bandwidth. The noise floor of the LO will need to be such that the noise is at -133dBm if degradation is not to occur, and this will be produced by a noise floor of -137dBc/Hz in the synthesiser at the frequency separation of the signals in question. Thus the high intermodulation performance may well be compromised by poor phase noise.

REFERENCES

- A1 A Table of Intermodulation Products, JIEE (London) Part III, 31-39 (Jan 1948) C.A.A. Wass.
- A2 A Re-appraisal of H.F. Receiver Selectivity, R.A. Barrs. Clerk Maxwell Commemorative Conference in Radio Receivers and Associated Systems, Leeds 1981. pp.213-226, Published by IERE, 99 Gower Street, London WC1E 6AZ. Conference Publication No. 50 ISBN 0 903 748 45 2.



HEADQUARTERS OPERATIONS
MITEL SEMICONDUCTOR
Cheney Manor, Swindon,
Wiltshire SN2 2QW, United Kingdom.
Tel: (01793) 518000
Fax: (01793) 518411

MITEL SEMICONDUCTOR
1500 Green Hills Road,
Scotts Valley, California 95066-4922
United States of America.
Tel (408) 438 2900
Fax: (408) 438 5576/6231

Internet: <http://www.gpsemi.com>
CUSTOMER SERVICE CENTRES

- **FRANCE & BENELUX** Les Ulis Cedex Tel: (1) 69 18 90 00 Fax : (1) 64 46 06 07
- **GERMANY** Munich Tel: (089) 419508-20 Fax : (089) 419508-55
- **ITALY** Milan Tel: (02) 6607151 Fax: (02) 66040993
- **JAPAN** Tokyo Tel: (03) 5276-5501 Fax: (03) 5276-5510
- **KOREA** Seoul Tel: (2) 5668141 Fax: (2) 5697933
- **NORTH AMERICA** Scotts Valley, USA Tel: (408) 438 2900 Fax: (408) 438 5576/6231
- **SOUTH EAST ASIA** Singapore Tel:(65) 3827708 Fax: (65) 3828872
- **SWEDEN** Stockholm Tel: 46 8 702 97 70 Fax: 46 8 640 47 36
- **TAIWAN, ROC** Taipei Tel: 886 2 25461260 Fax: 886 2 27190260
- **UK, EIRE, DENMARK, FINLAND & NORWAY**
Swindon Tel: (01793) 726666 Fax : (01793) 518582

These are supported by Agents and Distributors in major countries world-wide.

© Mitel Corporation 1998 Publication No. AN156 Issue No. 2.0 September 1993

TECHNICAL DOCUMENTATION – NOT FOR RESALE. PRINTED IN UNITED KINGDOM

This publication is issued to provide information only which (unless agreed by the Company in writing) may not be used, applied or reproduced for any purpose nor form part of any order or contract nor to be regarded as a representation relating to the products or services concerned. No warranty or guarantee express or implied is made regarding the capability, performance or suitability of any product or service. The Company reserves the right to alter without prior notice the specification, design or price of any product or service. Information concerning possible methods of use is provided as a guide only and does not constitute any guarantee that such methods of use will be satisfactory in a specific piece of equipment. It is the user's responsibility to fully determine the performance and suitability of any equipment using such information and to ensure that any publication or data used is up to date and has not been superseded. These products are not suitable for use in any medical products whose failure to perform may result in significant injury or death to the user. All products and materials are sold and services provided subject to the Company's conditions of sale, which are available on request.

All brand names and product names used in this publication are trademarks, registered trademarks or trade names of their respective owners.